

Science Y6 Summer 2 – Electricity

In this unit of work the children will match circuit symbols to their meaning and their words. They will predict and investigate what happens when more objects are added into a circuit and explain their results. They will investigate which materials are good conductors and which are insulators.

In this unit children will:

- Associate the brightness of a lamp or the volume of a buzzer with the number and voltage of cells used in the circuit.
- Compare and give reasons for variations in how components function, including the brightness of a bulb, the loudness of a buzzer and the on/off position of switches.
- Use recognised symbols when representing a simple circuit in a diagram.
- Predict, then investigate, carrying out a fair test what happens when more batteries, bulbs or motors are added to a circuit.
- Design and make a useful circuit – traffic light/burglar alarm
- Does the number of cells affect the brightness of a bulb in the circuit? Show results in a scatter graph

Prior Learning

Y4- Name electrical appliances, construct a simple circuit, conductors and insulators.

Cross Curricular Links

Key Vocabulary

Ammeter – Measures the current in a circuit.

Cell – Another word for a battery.

Circuit– A complete route which an electrical circuit can flow around.

Component–The parts that something is made of.

Conductor– A substance that heat or electricity can pass through or along.

Current– A flow of electricity through a wire or circuit.

Generate – Cause it to begin and develop.

Insulator–A non-conductor of electricity or heat.

Mains – Where the supply of water, electricity, or gas enters a building.

Motor – A device that uses electricity or fuel to power movement.

Power – Power is energy from a fuel source.

Resistance– A force which slows something down.

Resistor – A part of an electrical circuit that provides resistance to some of the current.

Switch – Control for an electrical device.

Voltage – Force of an electrical current is measured in volts.

Key Knowledge

- Electricity travels at the speed of light. That's more than 186,000 miles per second.
- Electricity is a type of energy that builds up in one place (static), or flow from one place to another (current electricity).
- Coal is the biggest source of energy for producing electricity. Coal is burned in furnaces that boils water and creates steam.
- The brightness of a bulb is associated with the voltage.
- You can make bulbs brighter by adding more batteries to the circuit.
- Adding more bulbs to a simple circuit will reduce the electrical energy and make bulbs dimmer.
- Lengthening the wires in a simple circuit will reduce the electrical energy, as it has further to travel. The extra distance will make the bulb dimmer.
- Electrical circuits can be represented by circuit diagrams and that the various electrical components are shown by using standard symbols.
- Shortening the wires means the electrons have less resistance to flow through.

Which of these circuits would work and which wouldn't?
How do you know?

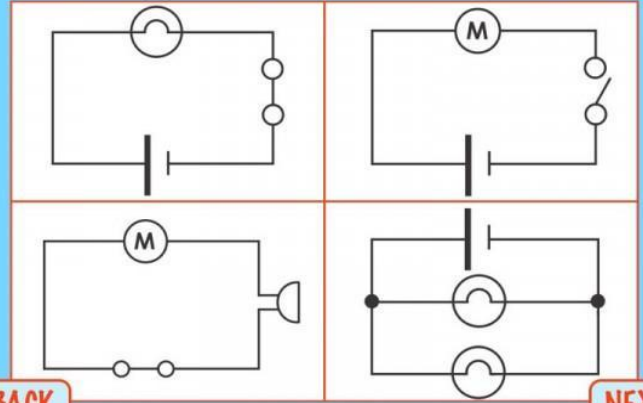

BACK

NEXT

www.planbee.com

- A conductor is a material that allows charges to flow throughout the material. Metals are often good conductors and include silver, gold, copper, steel and salt water. An insulator is a material that doesn't allow charges to flow through the material e.g. rubber, glass and oil.

Key Questions

- What will happen if another battery is added to a circuit with a bulb?
- What will make a circuit stop working?
- What will a conductor do when added to a circuit?
- Will shorter wires make bulbs brighter?
- What is the function of an ammeter in a circuit?